

EN

BLU2GO



blupura

ALWAYS COOLER

BLU2GO

60
lt/h



Gas
R290



Ice
Bank



Touch
Screen



Portion
Control



Vandal
Proof

THE FUTURE OF THE WATER VENDING MARKET IS SMART,
PLASTIC-FREE AND ZERO-KM.

BLU2GO is the new generation water vending machine which is connected to the mains water supply network. It delivers 4 different types of water into cups or bottles and allowing the purchase of a high-quality 500ml thermal water bottle or simply just cleansing.

By providing various types of water, high-quality service, maximum hygiene, technology and multiple payment systems, BLU2GO is the best solution which paves the way for a sustainable future in the water vending industry by significantly reducing plastic consumption.





Dispensing types

BLU2GO fills water bottles of 750 and 500ml and dispenses 170ml of water with or without a cup. It provides still room-temperature water, still, sparkling and semi-sparkling cool water. The dispensing area is 32 cm tall, LED illuminated and features a proximity sensor and anti-drip system.



Water bottle purchase

BLU2GO not only dispenses water, but also promotes the use of reusable water bottles. Thanks to its large built-in dispenser for storage (maximum capacity: 40 items) BLU2GO can sell high-quality stainless steel 500ml water bottles of Blupura Inox Bottle model only. Water bottles can be customized if required.



Water bottles sanitation

BLU2GO not only gives the opportunity to fill any kind of reusable water bottle, but it also offers the option of washing and cleaning the most popular water bottles made of stainless steel, glass, aluminum and food grade plastic in an effective and natural way.



Multiple payment systems (MDB)

BLU2GO can be equipped and enabled with different payment methods: coins, prepaid RFID cards and credit cards.



Hot-painted sheet metal load-bearing structure and tempered safety glass front panel.

The chambers for vending, washing and cleansing of water bottles adopt a locking system featuring safety sensor-based securing of the system.



Control panel

A flat and elegant control panel: stylish design, intuitive to use for a perfect purchase experience, maximum convenience, for easy cleaning of the controls.



Cup dispensing

BLU2GO also delivers single doses of water in 7cm diameter, reusable paper ecological cups, perfect for the automatic dispensing system. This system can contain up to 350 Blupura type paper cups.



Blupura Inox Water Bottle



Keeps your water warm or cold for 12 hours.



Made of Stainless Steel



Airtight seal



Safe, hygienic food grade material

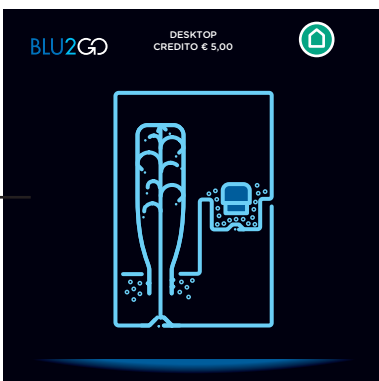

Water bottle internal cleaning

Stainless Steel, glass, aluminum or food grade plastic water bottles with their own caps, can be sanitized through different phases by a safe and ecological process thanks to natural products:

- Pre-wash with filtered water
- Wash with ozone
- Rinse with filtered water



By using cooling natural gases only, BLU2GO is eco-friendly and offers a more silent compressor. Thanks to its minimal design, stylish and convenient, it perfectly fits into every dining area and vending point. The intuitive, multilingual and animated user interface guarantees a linear and easy-to-use experience.



The interface for managers and technicians is also simple and immediate, together with maintenance operations. The reserved menu featuring Wi-Fi connectivity has two levels of access: administrator or technician, in order to allow an ideal and complete machine management operation, with electronic control of alarms, counters and events check.

A MULTILINGUAL, VISUAL AND HIGHLY INTUITIVE INTERFACE WHICH FEATURES A BUILT-IN, 15.6" HD TOUCHSCREEN DISPLAY: OBTAINING DRINKING WATER HAS NEVER BEEN THIS EASY.

The multilingual visual menu based on animated icons helps the user in every purchasing decision.



The display has an easy access menu, in compliance with the strict ADA regulations (Americans with Disabilities Act), to ensure use by people with disabilities.



By following the icons, the selection of the support (glass, cup or bottle) and the type of water preferred is fast and easy.



The volume filling operation into bottle, glass or cup size can be automatically set by the use of Portion Control, but also managed by the user which can stop the water flow at will.



The interface helps the user in any operation thanks to the intelligence of BLU2GO: from the correct positioning of the flask for filling, collecting, washing and also the sanitization process.

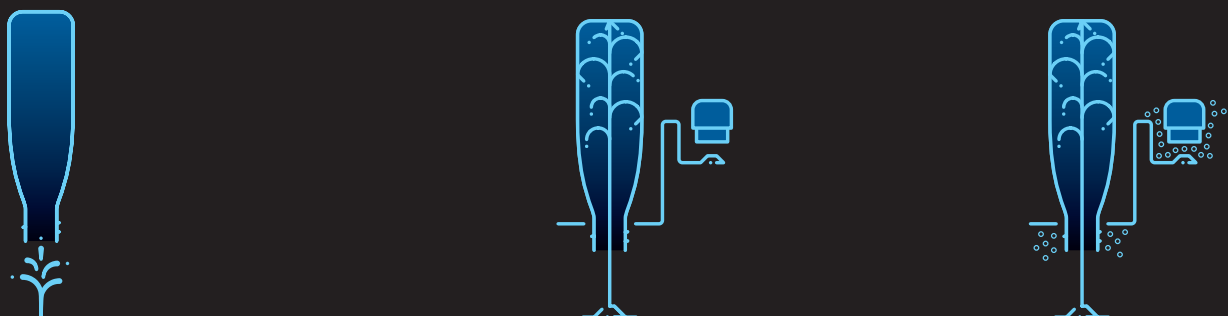

The highest hygiene and safety optimised for filtered and purified water guaranteed by Blupura.

Drinking water from the BLU2GO dispenser erases any risk associated with transport and storage of bottled water and always guarantees fresh water, dispensed by a perfectly hygienic system, closed and without stagnation, thanks to the numerous methods of filtration used.

The filtration system consists of:

- in-line UVC lamp fitted at the water inlet
- double microfiltering system that retains all impurities up to 0.5 microns
- high energy efficiency filtration that reduces the bacterial proliferation up to 99.999%
- UVC Out Ultra lamp which is fitted at the water dispense point

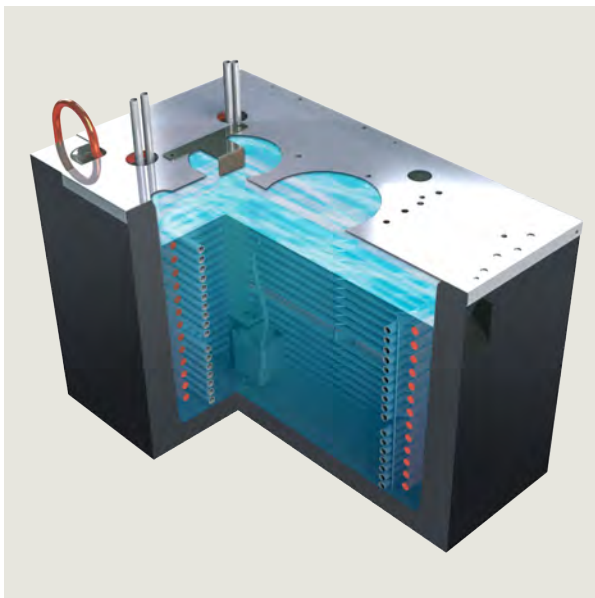
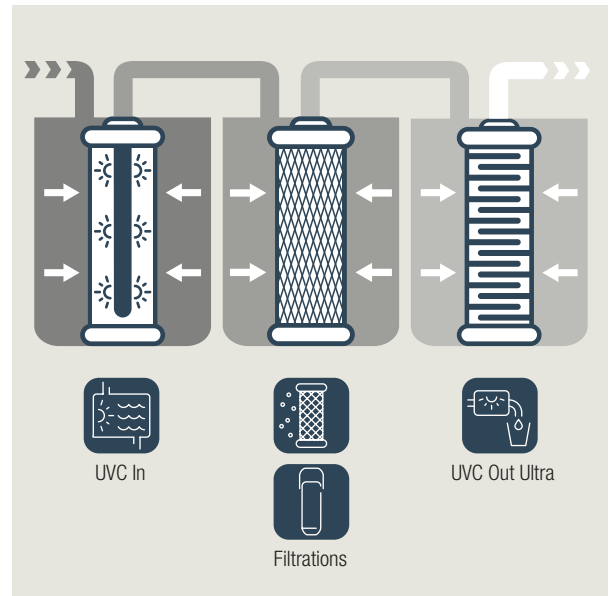

Ice Bank

The best-performing professional cooling technology ever. The water and refrigerant gas coils are immersed in an ice bank to ensure maximum performance and increased reliability.

Interior space for CO₂ cylinders

In the internal compartment, secured by a customizable lock, there is space for the main 10kg cylinder and a 4kg reserve cylinder. There is also a waste water collection tank with a 16 litre capacity and level control.

State-of-the-art security

Automatic periodic/scheduled flush to maintain water circuits to the highest level of hygiene.

Automatic sanitization following each bottle wash with ozone to sanitize the area when not in use.

Dispensing area protection with automatic closing of the water dispensing area and glass to protect from external agents. Bottle washing area protection with block closure of the wash drawer and sealing gasket of the area.

Easy cleaning and external sanitation made possible by the glass display, a perfectly smooth surface that can be easily and quickly cleaned.





Fizz



Medium



Ambient



Cold



Wash and
cleaning



Purchase of
water bottles



Portion Control



Dispensing
area



Weight



Dimensions

Lt./h

He [mm]

[kg]

W x D x H [mm]

	Lt./h	Fizz	Medium	Ambient	Cold	Wash and cleaning	Purchase of water bottles	Portion Control	Dispensing area	Weight	Dimensions
Blu2Go	60	•	•	•	•			•	320	190	615 x 735 x 1850
Blu2Go with washing and cleaning system	60	•	•	•	•	•		•	320	190	615 x 735 x 1850
Blu2Go with washing, cleaning and bottles purchasing system	60	•	•	•	•	•	•	•	320	190	615 x 735 x 1850

OPTIONAL EXTRAS

Blutron Micro 24K + Blutron Head



or

Blutron Ultra 10K + Blutron Head



CO₂ pressure reducer with 2 pressure gauge



Integrated vending cup dispenser
(to be included at the time of order)



Rear bracket with the possibility of wall fixing



Blupura cup (1.000 pz.)



Coin payment system
(to be arranged with your sales representative)



Inox bottle (neutral or with Blupura brand)

TECHNICAL PROFILE

Blu2Go

Cooling capacity [Lt./h.]	60
Power supply	230 V - 50 Hz
Professional carbonation pump	Membrane carbonation pump
Cooling technology	Ice Bank - Single Stainless Steel coil
Ice Bank Capacity [Lt.]	7
Ice Bank [Kg]	3
Condensation	Ventilated Condensation
Power consumption [W]	390
Max absorption [A]	2,05
Material Materials	Stainless steel and tempered glass

Given its commitment to continuous technological development, Blupura reserves the right to enhance or modify the products shown in this catalogue without prior notice.

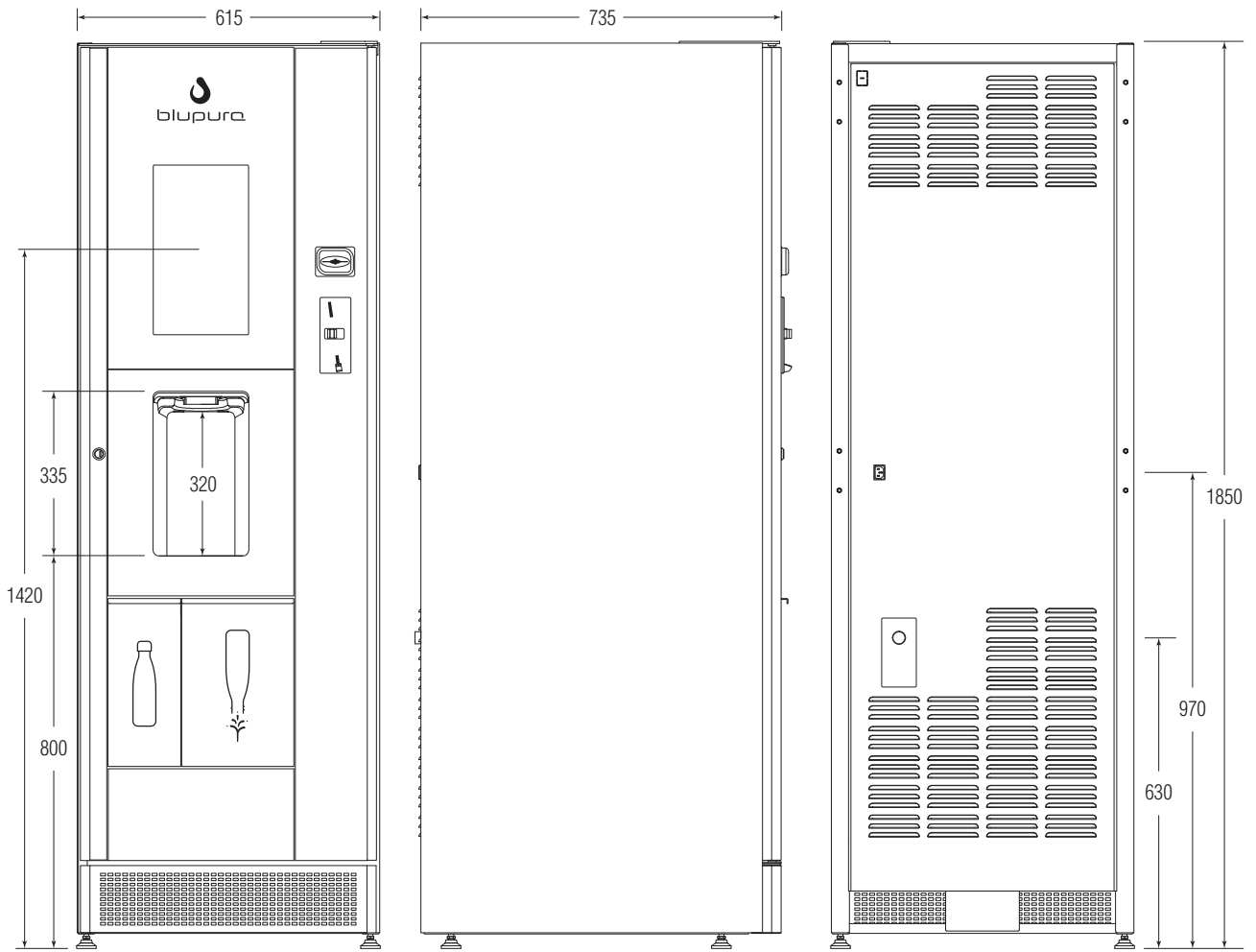

Easy handling with Forklift, 54 cm forks

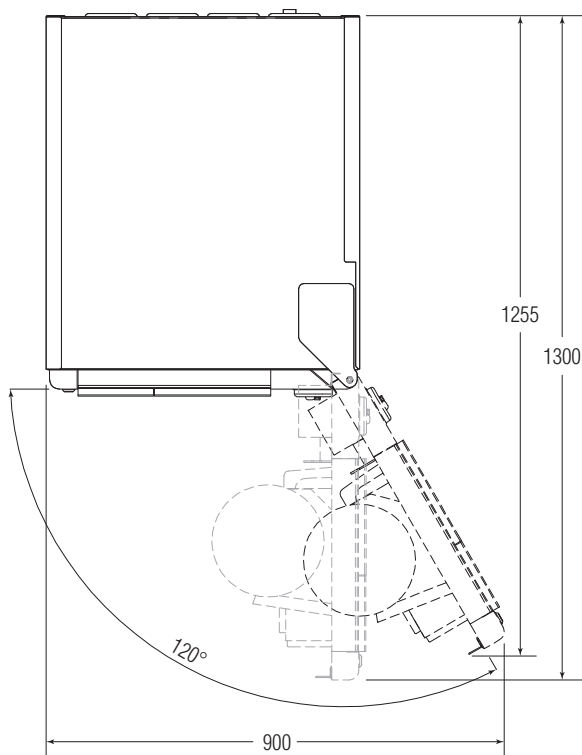



blupura

ALWAYS COOLER

Blupura S.r.l. - Via Volponi, 11 - 62019 Recanati (Mc) - Italy
Tel. +39 071 971 0080 - info@blupura.com

Blupura Usa - 1200 Brickell Ave, Suite 1950 - Miami (FL) 33131 - USA - Tel. +1 305 777 3591 - blupurausa@blupura.com
www.blupura.com

